

CITY OF BELOIT

REPORT TO THE BELOIT LANDMARKS COMMISSION



Meeting Date: July 15, 2014

Agenda Item: 5

File Number: COA-2014-25

Applicant: Beloit College

Owner: Beloit College

Location: 726 Church Street & 815 College Street

Existing Zoning: PLI, Public Lands and Institutions District, WPO, Wellhead Protection Overlay District

Existing Land Use: College Facilities

Parcel Size:

726 Church: .2850 Acre

815 College: .6990 Acre

Request Overview/Background Information:

Beloit College has submitted an application for a Certificate of Appropriateness (COA) for various site improvements to the properties located at 726 Church Street and 815 College Street. These properties are in the Near East Side/College Park Historic District. Section 32.06 of the Historic Preservation Ordinance grants the Landmarks Commission the authority to issue a Certificate of Appropriateness prior to the alteration of properties in historic districts.

Consistency with the Historic Preservation Ordinance and Strategic Plan:

This request is consistent with the intent and purpose of the Historic Preservation Ordinance and Strategic Goal #5.

Key Issues:

- **726 Church Street:**
 - During the Beloit Intensive Survey, the property was classified as a pivotal site in the Near East Side/College Park Historic District. A copy of the Intensive Survey Form is attached to this report.
 - The applicant had proposed and been approved for sponge-blasting for paint removal and spot-replacement of shingles at this property. They have since opted to scrape and paint the property. This does not require Commission or Staff approval.
 - The applicant is currently seeking approval for spot fascia, sill, and soffit repairs to the property. The attached photos detail the deteriorated sections of the property.
- **815 College Street:**
 - During the Beloit Intensive Survey, the property was classified as a contributing site in the Near East Side/College Park Historic District. A copy of the Intensive Survey Form is attached to this report.
 - The applicant had been previously denied a COA to remove the front two-story porch at this property. They are now proposing a COA for repairs to the porch.
 - This project will include the replacement of six (6) column capitals, making structural repairs as needed, patching plaster and wood fascia, repair/replacement of concrete, and painting of the entire structure.
- The proposed site improvements satisfy the standards of Section 32.06(6)(c) of the Historic Preservation Ordinance.

Sustainability:

- **Reduce dependence upon fossil fuels** – N/A
- **Reduce dependence on chemicals and other manufacturing substances that accumulate in nature** – N/A
- **Reduce dependence on activities that harm life sustaining eco-systems** – N/A
- **Meet the hierarchy of present and future human needs fairly and efficiently** – N/A

Staff Recommendation:

The Planning & Building Services Division recommends **approval** of a Certificate of Appropriateness for various site improvements at the properties located at 726 Church Street and 815 College Street, based on the standards and criteria contained in the Historic Preservation Ordinance and subject to the following conditions:

1. All architectural details and woodworking/craftsmanship shall be maintained and/or replicated through the repairs of fascia, sills, and soffits at 726 Church Street.
2. All work shall be completed by July 15, 2015.
3. Any changes or additions to this Certificate of Appropriateness must be reviewed and approved by staff prior to the start of any work. Work done without prior approval will be subject to the issuance of correction orders or citations.

Fiscal Note/Budget Impact: N/A

Attachments: Photos, Application, and Intensive Survey Forms.

726 Church Street



2nd Floor soffit



South side lower soffit/window



North Side windows





**815 College Street,
Proposed Porch Repairs**



16" Temple of Wind

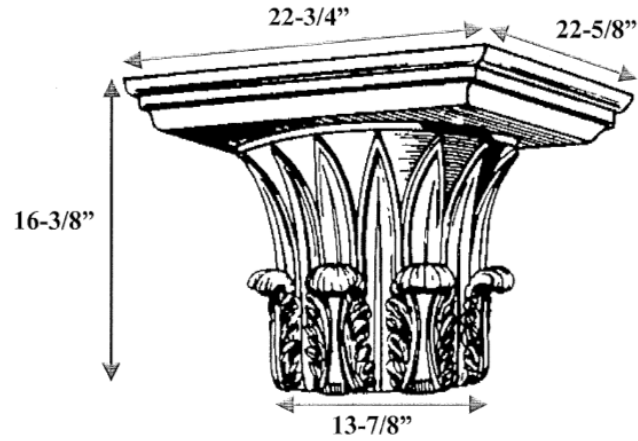

Specifications

Item #	T16-44
Material	Resin and marble composite
Load Bearing	Yes
Capital Weight	95 lbs
Shipping Weight	124 lbs
Base	13-7/8"
Inside Ring	7-5/8" (ring not shown)
Outside Ring	9-3/8"
Height	16-3/8"
Abacus	22-3/4" x 22-5/8"



CITY of BELOIT

PLANNING AND BUILDING SERVICES DIVISION

100 State Street, Beloit, WI 53511

Phone: (608) 364-6700

Fax: (608) 364-6609

CERTIFICATE of APPROPRIATENESS APPLICATION

(Please Type or Print)

File Number: COA-1014-25

1. Address of property: 815 College St, 726 Church St
2. Parcel #: 13670545, 13670025
3. Owner of record: Beloit College Phone: 608-363-2200
700 College St Beloit WI 53511
(Address) (City) (State) (Zip)
4. Applicant's Name: Tom Viel
700 College St Beloit WI 53511
(Address) (City) (State) (Zip)
608-363-2200 / (Office Phone #) (Cell Phone #) 1 viel@beloit.edu (E-mail Address)

5. Present use of property: _____

6. The following action is requested:

- Approval of COA by Landmarks Commission (projects not listed below)
- Approval of COA by staff: (Check all that apply)
- Roof repair/replacement
 - Gutter repair/replacement with historically appropriate materials and in historically appropriate styles
 - Private sidewalk and driveway repair/replacement with historically appropriate materials in the same dimensions, placement and orientation
 - Installation of historic plaques (residential properties only)
 - Chimney repair and tuckpointing according to the Secretary of the Interior standards and in historically appropriate color and design
 - Installation of fences
 - Storm window/storm door repair or replacement
 - Installation of glass blocks in basement window openings

Please continue to #7 (Over)

CERTIFICATE of APPROPRIATENESS APPLICATION (continued)

7. Description of Project: Describe each item of the project separately.

Project item: Include existing condition(s) when describing item. Also describe the proposed work, material(s) to be used, and the impact the item would have on existing historic or architectural features of the property. (Attach additional sheets if necessary.)

815 This project will replace the 6 column capitals, make structural repairs as needed, patch plaster, patch wood at fascia, replace/repair concrete and prime/paint the entire structure
 726 Church scrape pine paint to match existing and make all needed repairs to fascia, gully, porch, railing, soffits

8. Attachments:

- Site Plan of the lot (Please indicate direction of north, dimensions, structures, etc.)
- Sketches, drawings, building and streetscape elevations, and/or annotated photos
- Exterior photos
- Specifications (materials) for the project
- Phased development plan for the project (if proposed in phases)
- Inspection report (required for demolition requests only)
- Cost estimates for all the proposed work
- Other (please explain): _____

9. Source of Funds: Please indicate if funds for the project are being secured from any of the following sources:

- NHS City of Beloit SHSW Federal

NOTE:

The Beloit Landmarks Commission meets at 7:00 PM on the third Tuesday of the month. Meetings are held in The Forum of Beloit City Hall, 100 State Street. Applications must be filed with the Neighborhood Planning Division by the filing deadline date prior to the next Landmarks Commission meeting.

If you have questions or need assistance in completing this form, contact the City of Beloit Neighborhood Planning Division (364-6700).

Thomas Glad Thomas L. Viel 7/8/14
 (Signature of applicant) (Print name) (Date)

Review fee: \$50.00* / \$25.00* if staff approved Amount paid: \$ <u>50.00</u>
<small>* Review fees are doubled to \$100.00 and \$50.00, respectively, when work begins prior to issuance of a COA.</small>
Scheduled meeting date: <u>7/15/14</u>
Application accepted by: <u>S. Hummel</u> Date: <u>7/8/14</u>

INTENSIVE SURVEY FORM Historic Preservation Division State Historical Society of Wisconsin

1	City, Village or Town: BELOIT	County: ROCK	Surveyor: Richard P. Hartung	Date: July, 1981	Street Church	
	Street Address: 726 Church Street	Legal Description: Lot 4, Block 27, Original Plat	Acreage:			
	Current Name & Use: Residence		Current Owner: Board of Trustees, Beloit College			
	Film Roll No. RO-86 *RO-111		Current Owner's Address: 700 College Avenue, Beloit, Wisconsin			Number 726
	Negative No. 2 *18, 19		Special Features Not Visible In Photographs:			
	Facade Orient. E		Interior visited? <input type="radio"/> Yes <input checked="" type="radio"/> No			

2	Original Name & Use:	Source	Previous Owners	Dates	Uses	Source	Town
	Anna Pratt House						
	Dates of Construction /Alteration	Source					Range
	1890	A					
	Architect and/or Builder:	Source					

3	Architectural Significance <input type="radio"/> Represents work of a master <input type="radio"/> Possesses high artistic values <input checked="" type="radio"/> Represents a type, period, or method of construction <input type="radio"/> Is a visual landmark in the area <input type="radio"/> Other: _____ <input type="radio"/> None	4	Historical Significance <input type="radio"/> Assoc. with lives of significant persons <input type="radio"/> Assoc. with significant historical events <input type="radio"/> Assoc. with development of a locality <input type="radio"/> Other: _____ <input checked="" type="radio"/> None	Section
	Architectural Statement:		Historical Statement:	

<p>This large residence, built in 1890, is an architecturally significant example of the Queen Anne style in Beloit. Rising two stories plus attic, the frame house has a complex roof line with hip and gabled elements. A series of rounded, square and chamfered bays project from the facade, while the cross gables are pedimented and feature heavy cornices. But the most remarkable feature of the house is the variegated siding. Smooth and narrow clapboarding wraps tightly around the first story while shingles in a reticulated pattern animate the upper stories with (over)</p>	<p>Mrs. Gertrude Pratt bought the property located at 726 Church from William Porter in 1889. The beautifully crafted house was built in the next year, 1890. Mrs. Pratt lived here until 1924, when she sold it to E. B. West of Illinois. (A)</p>
--	---

5	Sources of Information (Reference to Above)	6	Representation in Previous Surveys	Map Name Near East Side Historic District
A	Beloit Tax Rolls, RCHS Archives		<input type="radio"/> HABS <input type="radio"/> NAER <input checked="" type="radio"/> WIHP <input type="radio"/> NRHP <input type="radio"/> landmark <input type="radio"/> other: _____	
B		7	Condition	
C			<input checked="" type="radio"/> excellent <input type="radio"/> good <input type="radio"/> fair <input type="radio"/> poor <input type="radio"/> ruins	
D		8	District: Near East Side Historic Dist.	
E			<input checked="" type="radio"/> pivotal <input type="radio"/> contributing <input type="radio"/> non-contributing initials: R date: 8/1/81	
F		9	Opinion of National Register Eligibility	Map Code NES 86/2
			<input checked="" type="radio"/> eligible <input type="radio"/> not eligible <input type="radio"/> unknown <input type="radio"/> national <input type="radio"/> state <input type="radio"/> local initials: R	

726 Church Street

Architectural Statement (Continued)

movement and texture. The entry porch features heavy Eastlake-like porch posts and a perforated frieze, while Stick-like latticework ornaments the porch pediment and gables. Vergeboards, brackets, and a brick chimney rising through both stories and well above the roof ridge provide more variety to this Queen Anne home. The single most distinctive details are ogee shaped brackets on the front porch pillars; where the pillars are paired across the front these brackets meet to form a complete ogee arch.



INTENSIVE SURVEY FORM Historic Preservation Division State Historical Society of Wisconsin

1		City/Village or Town: BELOIT	County: ROCK	Surveyor: Richard P. Hartung	Date: July, 1981	Street BELOIT COLLEGE CAMPUS (College St.) Number 815 Town Range Section Map Name Near East Side Historic District Map Code NES 85/23	
		Street Address: BELOIT COLLEGE CAMPUS 815 College Street		Legal Description: Part of L. 13, & L. 14 & 15, B. 26, Original Plat	Acreage:		
		Current Name & Use: Music Department		Current Owner: Trustees of Beloit College			
Film Roll No. RO-85		Current Owner's Address: 700 College Street, Beloit, Wisconsin		Special Features Not Visible In Photographs:			
Negative No. 23		Prints		Interior visited? <input type="radio"/> Yes <input checked="" type="radio"/> No			
Facade Orient. W							
2		Original Name & Use: Phi Kappa Psi Fraternity	Source A	Previous Owners	Dates	Uses	Source
		Dates of Construction/Alteration 1952	Source B				
		Architect and/or Builder:	Source				
3		Architectural Significance <input type="radio"/> Represents work of a master <input type="radio"/> Possesses high artistic values <input type="radio"/> Represents a type, period, or method of construction <input type="radio"/> Is a visual landmark in the area <input checked="" type="radio"/> Other: None		4		Historical Significance <input type="radio"/> Assoc. with lives of significant persons <input type="radio"/> Assoc. with significant historical events <input type="radio"/> Assoc. with development of a locality <input type="radio"/> Other: <input checked="" type="radio"/> None	
		Architectural Statement: Two story plus attic Colonial Revival with a gambrel roof; red brick and stucco exterior. Two story colonade veranda with columns similar to those of Chapin Hall (CE 85/19). Large windows to floor on either side of large scale entry with (stock?) broken pediment, side lights and top light. Tips of pediment graze the window sill above. Awkward balustrade on top of veranda roof to create a balcony. Side wings have dormers.				Historical Statement: Site of Humphrey Foster house. See also ISF for 708 Clary.	
5		Sources of Information (Reference to Above)		6		Representation in Previous Surveys	
A		Information supplied by Robert H. Irrmann, College Archivist, October, 1981		<input type="radio"/> HABS <input type="radio"/> NAER <input checked="" type="radio"/> WIHP <input type="radio"/> NRHP <input type="radio"/> landmark <input type="radio"/> other:			
B		Information supplied by James Balch, Director of the Physical Plant, Beloit College, October, 1981		7		Condition	
C				<input checked="" type="radio"/> excellent <input type="radio"/> good <input type="radio"/> fair <input type="radio"/> poor <input type="radio"/> ruins			
D				8		District: Near East Side Historic Dist.	
E				<input type="radio"/> pivotal <input checked="" type="radio"/> contributing <input type="radio"/> non-contributing initials: R date: 2/1/81			
F				9		Opinion of National Register Eligibility	
				<input checked="" type="radio"/> eligible <input type="radio"/> not eligible <input type="radio"/> unknown <input type="radio"/> national <input type="radio"/> state <input type="radio"/> local initials: R			